

GP

di PIAZZON srl

SILOS E IMPIANTI DI STOCCAGGIO PER USO ESTERNO OUTDOOR SILOS AND STORAGE PLANTS

·su gonna ·su struttura ·skirt mounted ·frame mounted

FUNZIONI PRINCIPALI

SILOS DI STOCCAGGIO PER USO ESTERNO ED INTERNO DI GRANDI DIMENSIONI REALIZZATI IN ACCIAIO INOX ED ALLUMINIO.

MAIN FUNCTIONS

LARGE OUTDOOR AND INDOOR STORAGE SILOS MADE OF STAINLESS STEEL AND ALUMINIUM.

OPTIONAL

- FLUIDIFICATORI
- COCLEA ESTRATTRICE
- FONDO VIBRANTE
- ATEX
- COIBENTAZIONE
- OMOGENIZZATORE
- SCARICATORE TELESCOPICO
- SISTEMA DI SICUREZZA PER GESTIONE CARICO
- CELLE DI CARICO PER PESATURA
- CONTROLLO VOLUMETRICO AD ULTRASUONI
- STAZIONE CENTRALIZZATA DI CARICO

OPTIONALS

- FLUIDIZERS
- DISCHARGE SCREW
- VIBRATING BOTTOM
- ATEX
- INSULATION
- OMOGENISER
- LOADING BELLOWS
- SAFETY SYSTEM FOR LOAD CONTROL
- LOAD CELL WEIGHING SYSTEM
- ULTRASONIC VOLUME CONTROL
- CENTRALISED LOADING STATION

CARATTERISTICHE TECNICHE

- ANGOLO CONO TRA 45° E 60°
- MULTICAMERA
- SINGOLA CAMERA
- PARAPETTI DI PROTEZIONE E SCALE IN ALLUMINIO O ACCIAIO
- TUBAZIONI DI CARICO IN ACCIAIO INOSSIDABILE ANTIUSURA
- IDEALE PER STOCCAGGIO SOLIDI E LIQUIDI



TECHNICAL FEATURES

- CONE ANGLE BETWEEN 45° AND 60°
- MULTI-CHAMBER
- SINGLE CHAMBER
- ALUMINIUM OR STEEL SAFETY HANDRAILS AND LADDERS
- STAINLESS STEEL, WEAR RESISTANT INLET FILL PIPES
- IDEAL FOR STORAGE OF SOLIDS AND LIQUIDS



SILOS CON COCLEA ESTRATTRICE
PER CARICO AUTOBOTTE
SILOS WITH DISCHARGE SCREW FOR
LOADING TANK TRUCKS



SILOS NESTING PER OTTIMIZZARE
TRASPORTO SU NAVE
NESTING
SILOS



IMPIANTO DI STOCCAGGIO CON ZONA
DI CARICO CENTRALIZZATA
STORAGE PLANT WITH CENTRALISED
LOADING ZONE



SILO A DOPPIA O
TRIPLA CAMERA
TWO OR THREE
CHAMBERS SILOS

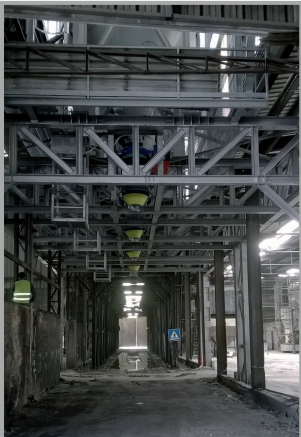

SILOS SU STRUTTURA CON SCARICATORE
TELESCOPICO PER CARICO AUTOBOTTE
SILOS WITH DISCHARGE SCREW FOR
LOADING TANK TRUCKS



SISTEMA DI
SICUREZZA
SAFETY
SYSTEM



SILOS E STRUTTURA
SU CELLE DI CARICO
SILOS AND FRAME
ON LOAD CELLS



SILOS ATEX CON PANNELLI ANTISCOPPIO
SU STRUTTURA IN FE ZINCATO
ATEX SILOS WITH EXPLOSION VENT
PANELS ON GALVANISED IRON FRAME



SILOS DI STOCCAGGIO
PER POLVERI
POWDER STORAGE
SILOS



SILOS DI STOCCAGGIO COIBENTATI CON IMPIANTO
DI FILTRAGGIO CENTRALIZZATO
INSULATED STORAGE SILOS WITH
CENTRALISED FILTERING SYSTEM

GP di PIAZZON srl

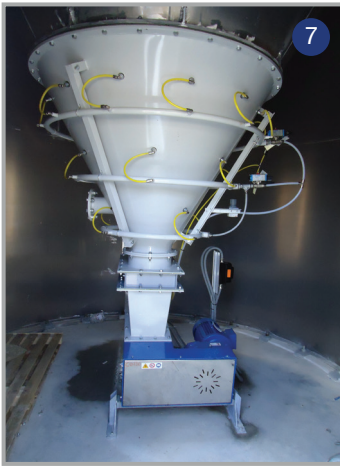

SILOS E IMPIANTI DI STOCCAGGIO PER USO ESTERNO

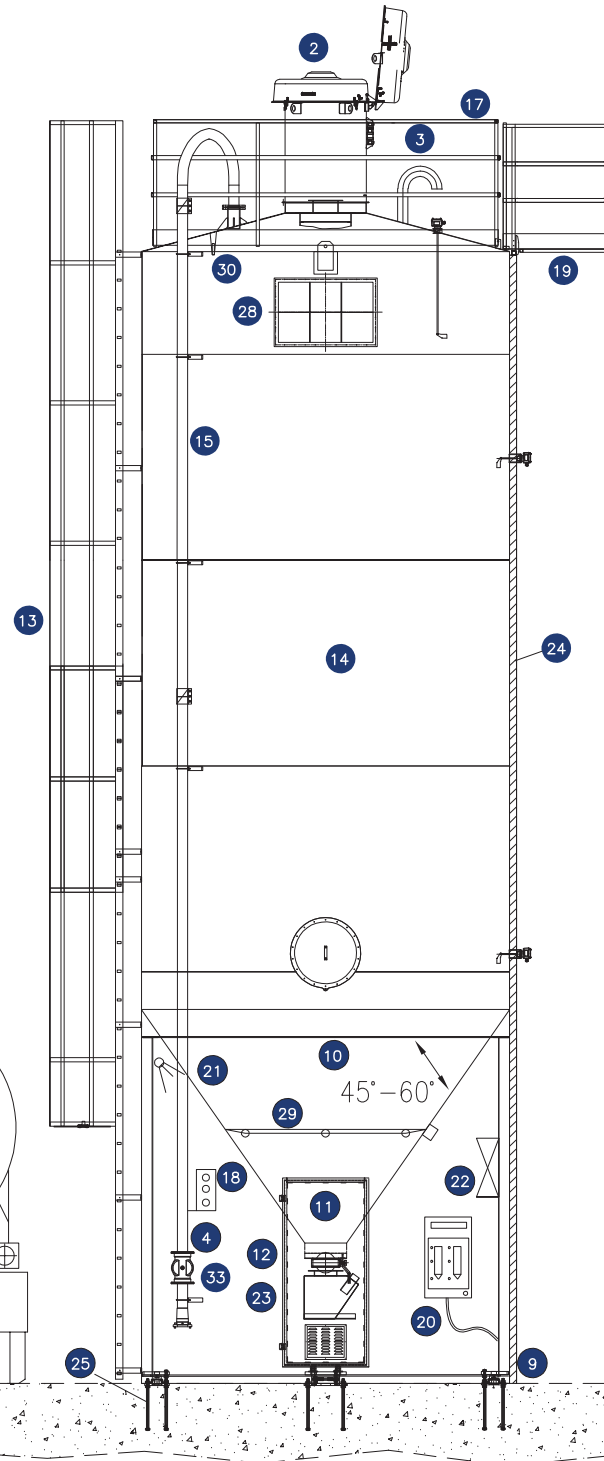

LISTA ACCESSORI

LEGENDA	DESCRIZIONE
1	filtro centralizzato
2	filtro
3	sfiato
4	valvola di intercettazione
5	valvola di sicurezza
6	livello
7	insufflaggi o martelli pneumatici
8	passaggio uomo
9	celle di carico
10	cono da 45° a 60°
11	porta di accesso
12	valvola a farfalla
13	scala di accesso
14	fascione
15	tubo di carico
16	cono vibrante
17	parapetto
18	allarme
19	passerella
20	quadro di controllo sinottico
21	impianto illuminazione
22	quadro di derivazione utilizzi
23	cassetta di aspirazione
24	coibentazione
25	dima per fissaggio tirafondi
26	livello radar o a onde filo guidate
27	sistema antincendio o raffrescante
28	membrana antiscoppio
29	sistema di deumidificazione
30	sensore temperatura e umidità
31	coclea estrazione
32	messa a terra attiva
33	sensore di pressione

OUTDOOR SILOS AND STORAGE PLANTS

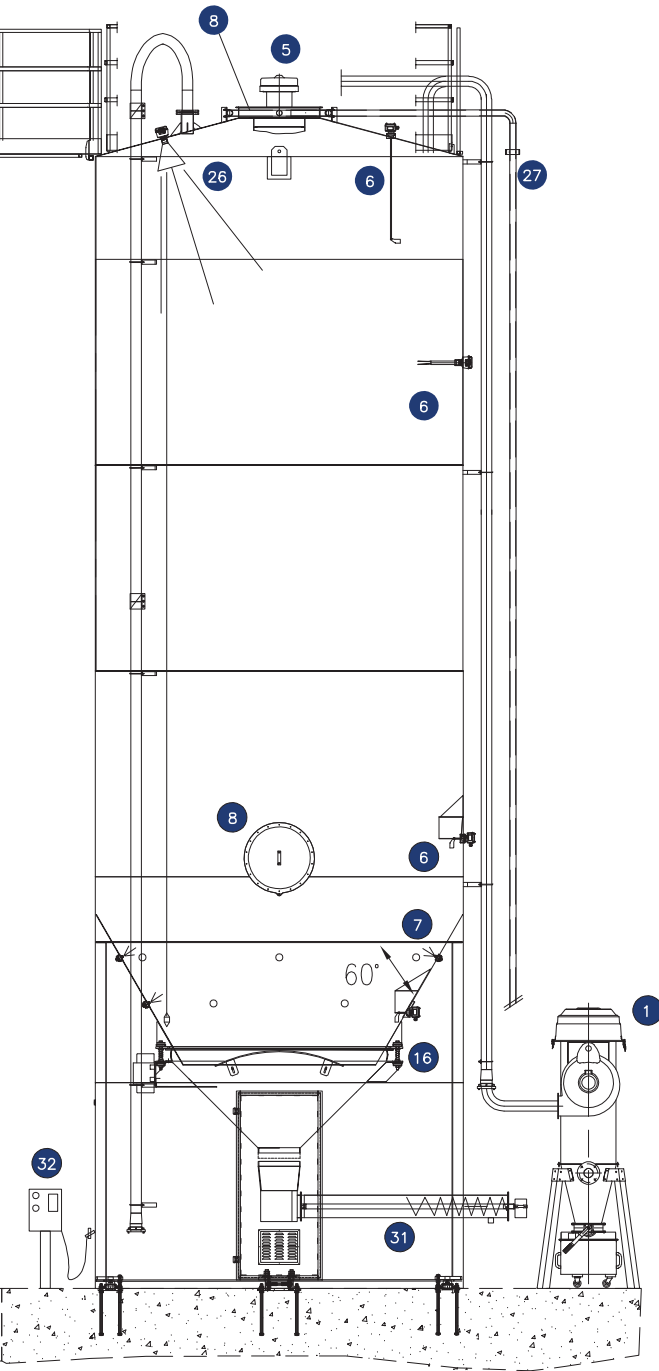

LIST OF ACCESSORIES

LEGEND	DESCRIPTION
1	centralized filter
2	filter
3	breather nozzle
4	interception valve
5	safety valve
6	level
7	pneumatic hammer and insufflation
8	manhole
9	load cell
10	cone from 45° to 60°
11	door
12	butterfly valve
13	stairs
14	cylinder
15	loading tube
16	vibrating cone
17	parapets
18	alarm
19	catwalk
20	synoptic panel
21	lightning system
22	derivation panel
23	suction box
24	insulation
25	template for fix the ground bolt
26	radar level
27	antifiresystem
28	anti-burst membrane
29	deumidification system
30	temperature and humidity sensor
31	extractor screw
32	electrical grounding
33	pressure sensor

SILOS CON DOPPIA/TRIPLA CAMERA CON FILTRO A TERRA | SILOS WITH DOUBLE/TRIPLE ROOM WITH GROUND FILTER

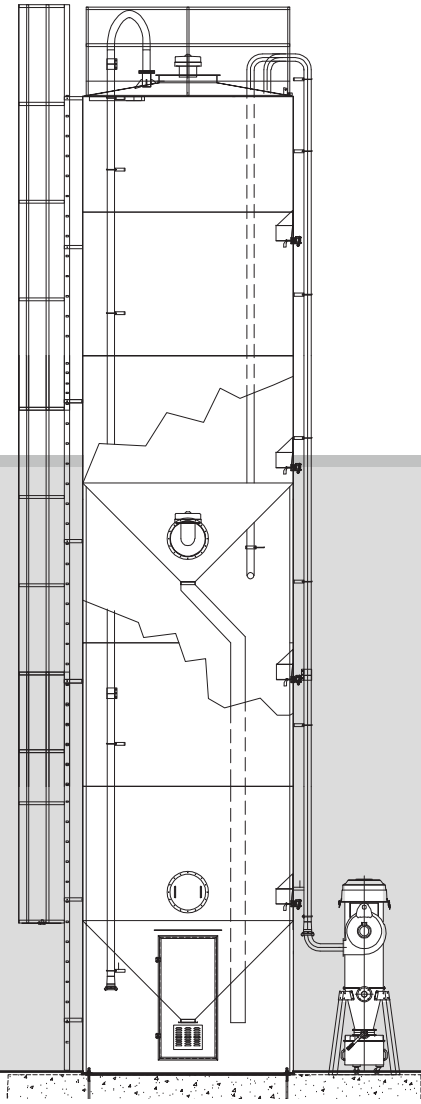

SILOS OMOGENIZZATORE | SILOS HOMOGENIZER

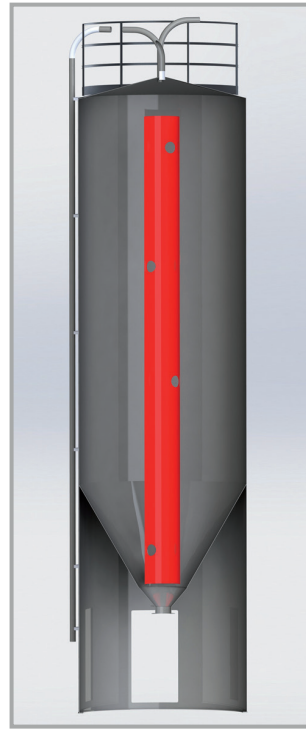
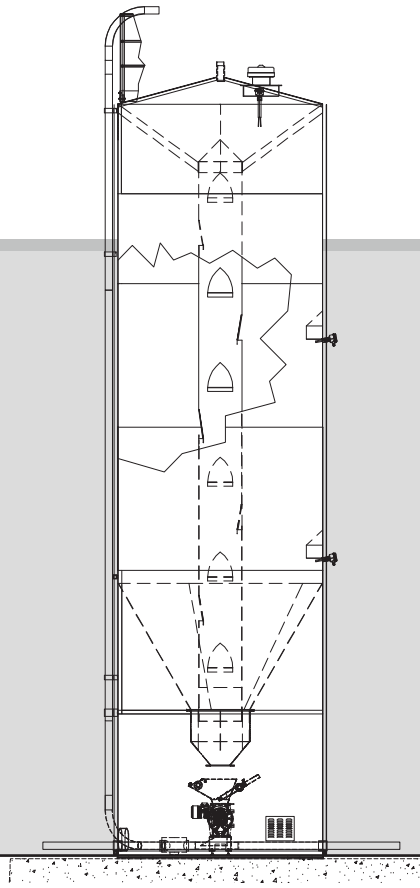

SILOS ESTENSIBILE PER OTTIMIZZARE TRASPORTO SU NAVE | EXTENSIBLE SILOS TO OPTIMIZE SHIP TRANSPORT

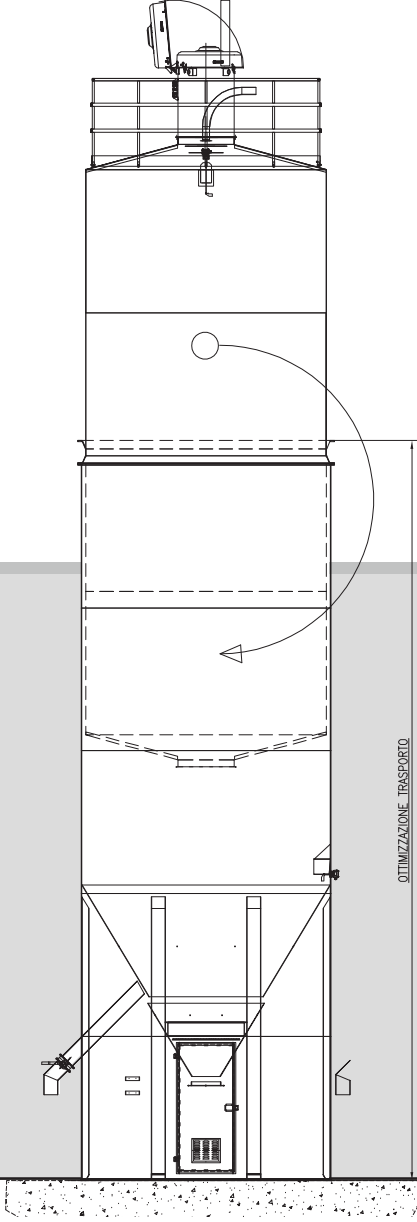

OTTIMIZZAZIONE TRASPORTO

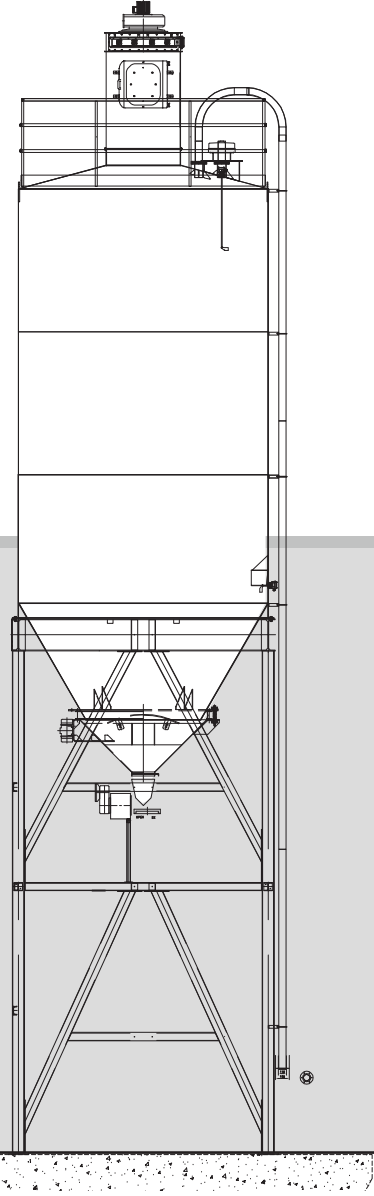

SILOS CON STRUTTURA | SILOS WITH STRUCTURE